



Overseas model shown.

Illustration may contain optional features to the model.

ENGINE

Power: 360hp (265kW) @ 2200 rpm
Torque: 1650Nm @ 1200rpm

TRANSMISSION

Allison 3200 Full Automatic

MASS RATINGS

GVM: 27600kg
GCM: 27600kg

WHEELBASE

4500mm | 4800mm

KEY FEATURES

- Compliant to Euro VI STEP E Emission standard
- Advanced Emergency Braking System
- Adaptive Cruise Control
- Lane Departure Warning
- Full LED Headlights with cornering fog lights
- 7" Infotainment system with Apple CarPlay®
- Climate control HVAC system

WARRANTY*

Standard Warranty
5 Years / 500,000km (whichever occurs first)

| | Driveline Only | Driveline & other components |
|----------------|----------------|------------------------------|
| Driveline | • | |
| Driveline Plus | • | • |

MAINTENANCE & REPAIR CONTRACTS*

| | Maintenance | Friction | Repair |
|--------------|-------------|----------|--------|
| Service Bond | • | | |
| Friction | • | • | |
| Easy Road | • | • | • |

Contracts available up to 5 years/500,000kms (whichever occurs first)
*Please refer to the 'Standard Inclusions List' at your IVECO dealer.

ENGINE

| | |
|--------------------|--------------------------|
| Engine Model | Cursor 9 |
| Total Displacement | 8710cm ³ |
| Maximum Power | 360hp (265kW) @ 2200 rpm |
| Maximum Torque | 1650Nm @ 1200rpm |

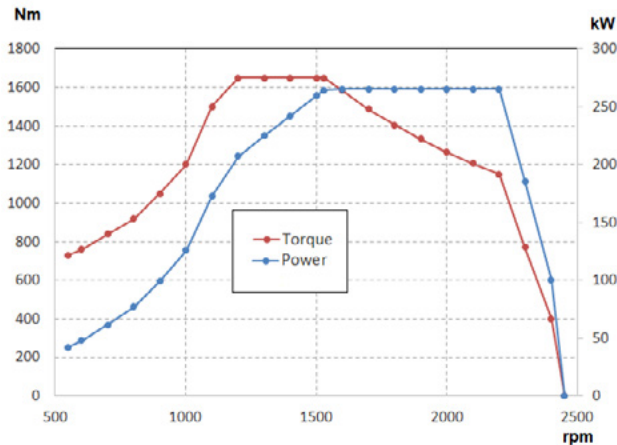

| | |
|------------------------|---|
| Injection type | Direct |
| Fuel Injection system | Common rail |
| Bore & Stroke | 117 & 135mm |
| After-Treatment System | Hi-e SCR after-treatment system with DOC: Diesel Oxydation Catalyst DPF: Diesel Particulate Filter SCR: Selective Catalytic Reduction CUC: Clean Up Catalyst |
| Emission Compliance | Euro VI STEP E |

TRANSMISSION

| | |
|---------------------|--|
| Description | Automatic Transmission |
| Make & Model | Allison 3200 |
| Shifter type | Dash mounted electronic shifter with column mounted sequential shifter |
| Gear ratios: | 1st: 3.49 5th: 0.75 2nd: 1.86 6th: 0.65 3rd: 1.41 Rev 5.03 4th: 1.00 |
| Torque converter: | Allison TC-418 |
| Stall torque ratio: | 1.77 |

POWER TAKE-OFF

| | |
|-------------------|---|
| Rear engine PTO | Without Rear Engine PTO |
| Gearbox Power PTO | Side mount PTO - Equipped |
| PTO Control | Equipped with activation switch and electrics |

REAR AXLE RATIO

| | |
|-----------------|------------------|
| Rear Axle Ratio | Standard: 5.67:1 |
|-----------------|------------------|

PERFORMANCE

| | |
|---------------------------------------|----------------------------|
| Engine RPM @ 100km/h | 1870 |
| Road speed limiter | 100km/h, Conforms to ADR65 |
| Gradeability ¹ @ Rated GVM | 34% |

¹This is theoretically calculated. Actual performance may vary under different conditions.

AXLE & SUSPENSION

| | |
|--|--|
| Front Axle Model & Type | IVECO 5890/D ON - Axle drop: 142mm |
| Front suspension | Parabolic suspension with dampers |
| FA & suspension capacity | 8000kg |
| FA group mass rating | 7100kg (with tyres) |
| Front Stabiliser bar | Diameter: ø45mm/ Roll rate: 3300Nm/Deg |
| Rear Axle Model & Type | MT23-150/D - Tandem Single reduction |
| Rear suspension | 8 Bellow air suspension with ECAS Stroke: Raise/lower - 125mm/-65mm |
| Rear dampers | Equipped |
| RA & suspension capacity | 23000kg |
| RA group mass rating | 21000kg (with tyres) |
| Rear Stabiliser bar | Diameter: ø60mm/ Roll rate: 8247Nm/Deg |
| Axle load indicator | Equipped (with pneumatic suspension only) |
| Differential Cross Lock | Equipped |
| Road friendly suspension Certification | RFCN: RF2103 |

BRAKES & AUXILIARY BRAKES

| | |
|---------------------------------------|--|
| Type/Control | Full air/Electronic Braking System (EBS) - ABS (Anti-lock Braking System) - ASR (Anti-Skid Regulator) - DPI (Direct Brake Integration) - BAS (Brake Assistant System) - BVR (Brake Lining Wear Adjustment) - ARB (Hill Holder) - ESC (Enhanced Stability Control) |
| Front axle | Ventilated Disc: Diameter 432mm/ Braking surface : 784cm ² |
| Rear axle | Ventilated Disc: Diameter 432mm/ Braking surface : 784cm ² |
| Engine brake with 3 level retardation | Equipped |
| Transmission Intarder | Optional |

CHASSIS

| | |
|-------------------------|---------------------------------------|
| Dimensions | 304.4x80x7.7mm |
| Chassis width (at rear) | 771.4mm |
| Material | Steel |
| Tensile strength | 610N/mm ² |
| Exhaust Pipe | Chassis mounted ATS & Horizontal pipe |
| Air Tanks | Aluminium |
| Front tow hook | Equipped |
| Towing cross member | N/A |

WHEELS & TYRES

| | |
|-----------|--|
| Rim Type | 10-Stud disc wheel (ISO type) PCD 335mm Finish: Brushed Alloy |
| Rim size | 22.5" x 8.25" |
| Tyre size | Front 295/80R22.5 Rear 295/80R22.5 |

FUEL & ADBLUE® TANK

| | |
|-----------------------------|------|
| Fuel Tank with lockable cap | 290L |
| AdBlue® Tank | 50L |

FUEL SAVING FEATURES

| | |
|---------------------|----------|
| Engine idle cut off | Equipped |
| EcoSwitch | Equipped |

SAFETY FEATURES

| | |
|--|----------|
| Electronic Stability Programme (ESP) | Equipped |
| Anti-lock Brake System (ABS) | Equipped |
| Anti-slip Regulator (ASR) | Equipped |
| Advanced Emergency Braking System (AEBS) | Equipped |
| Adaptive Cruise Control (ACC) | Equipped |
| Lane Departure Warning System (LDWS) | Equipped |
| Reverse Buzzer | Equipped |
| Daytime Running Lamp (DRL) | Equipped |
| ECE-R29 Cab Strength Certification | Equipped |
| ECE-R93 Front Underrun Protection (FUP) | Equipped |

ELECTRICAL & ELECTRONICS

| | |
|--|---------------------------------------|
| Voltage | 24V System |
| Batteries | 2x 12 Volt/220Ah Batteries |
| Electrical battery cutout | Optional |
| Battery position | Horizontal on side frame - LHS |
| Alternator | 28 Volt/90A |
| Fleet Management System data interface (FMS) | Equipped |
| Chassis mounted jump start plug | Equipped |
| CAN OPEN Bodybuilder interface | Equipped |
| LED Headlamp - Low beam | Equipped |
| LED Headlamp - High beam | Equipped |
| Daytime Running Lamp (DRL) | Equipped |
| Fog light with cornering & bending | Equipped |
| Provision for roof rotating lights | Equipped with harness & switch in cab |
| Chassis mounted pneumatic horn | Equipped |

STEERING

| | |
|--|---|
| Telescopic & Tilt adjustable steering column | Equipped |
| | Soft touch steering wheel with following: - Controls for the information screen - Controls for the phone |
| Steering wheel | - Activation for voice recognition - Controls for ACC (Adaptive cruise control) - Controls for radio/media volume |
| Steering angle | Inside: 52° Outside: 36° |

SERVICE INTERVALS

| | |
|---|--------------------|
| Engine oil change interval ² | 50,000km/12 Months |
|---|--------------------|

²Based on normal operating conditions and may be reduced when operating under severe conditions.

CAB EXTERIOR

| | |
|--------------------|---|
| Cab type | Low roof Day cab (AD) |
| Cab tilt mechanism | Servo assisted cab tilt mechanism |
| Cab mounting | Mechanical suspension front & rear |
| Windscreen Wipers | Automatic - Rain sensing 2 Speed with Integrated Washer Nozzles |
| Front Bumper | Multi-piece Plastic front bumper with foldable step Optional: Multi-piece hybrid front bumper with foldable step |

| | |
|-------------------|---|
| Rearview mirrors | 2 x Motorised, heated flat main mirrors & convex spotters 1 x LHS kerb view & front view mirrors |
| External Sunvisor | Equipped |
| Colour | White IC 194 |

CAB INTERIOR

| | |
|-------------------------------|--|
| Seating capacity | Two |
| Driver Seat | Fabric, Air suspended, Heated, 3-Way adjustable seat |
| Passenger Seat | Fabric, Air suspended, Heated, 3-Way adjustable seat |
| Seat Belt | 3-point Lap/Sash type |
| Sun visor & overhead consoles | Equipped on both driver & Passenger side 7" LCD HD touch screen display DAB + AM/FM radio USB input, Bluetooth® connectivity Smart phone mirroring Apple CarPlay® |
| Multimedia unit | Voice recognition In built Tom Tom Satellite navigation system Reverse/Side camera compatible USB charging ports (TYPE A) 12 Volt power socket |
| HVAC System | Equipped - with climate control |
| Immobiliser | Equipped - with 3 x remote central lock keys |
| Power Windows | Equipped |
| Cup holders | Equipped |
| Interior lighting | LED Internal Lights |
| Rollup sun blinds for doors | Equipped |

GENUINE ACCESSORY OPTIONS

| | |
|--------------------|---------------------------------|
| - Phone Cradle | - Rubber Floor Mats |
| - Cameras | - Seat Covers |
| - Foot Well Liners | - 24 to 12 Volt Voltage Reducer |

Please check with your dealer for availability and price.

IVECO TELEMATICS

| | |
|--|---|
| Telematics Hardware | Equipped (GSM & GPS & Antenna & 4G SIM) with provision for mobile cradle. |
| | Upon subscription. Features include: - MYIVECO Smart report |
| Smart connectivity pack (Included for 5 years) | - MYIVECO Web portal & mobile app - MYIVECO Vehicle monitoring & remote assistance - MYIVECO Easy Way app |
| Premium pack | Optional |

MODEL CODE: AD230A36Z/P

Application: Rigid

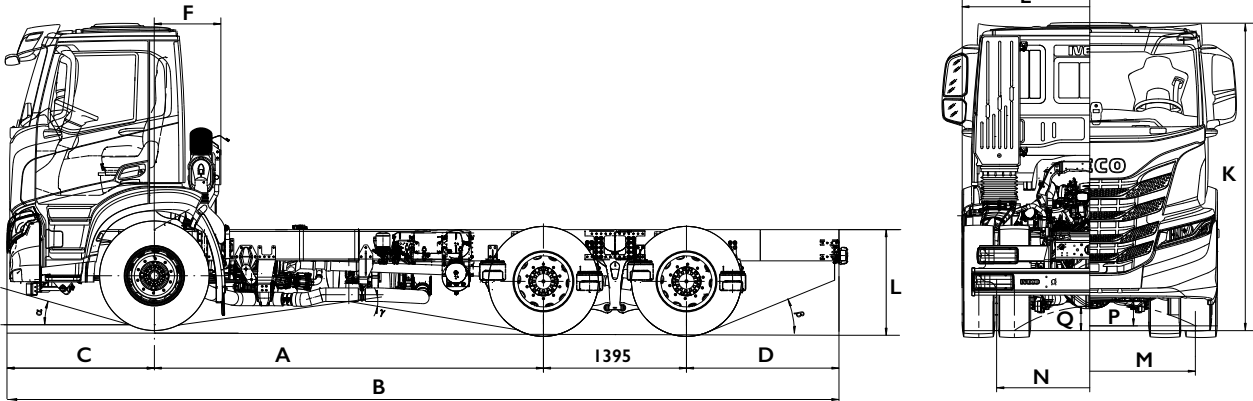

DIMENSIONS & WEIGHTS

| | | |
|--|-------|-------|
| Wheelbase - A (mm) | 4500 | 4800 |
| Max length - B (mm) | 9349 | 9169 |
| Max width over fenders - E (mm) | | 2500 |
| Front axle to back of cab - F (mm) | | 650 |
| Frame height at end of frame, unladen - L (mm) | 1031 | 1029 |
| Front overhang - C (mm) | | 1410 |
| Rear overhang - D (mm) | 1983 | 1488 |
| Minimum ground clearance, front - P (mm) | | 231 |
| Minimum ground clearance, rear - Q (mm) | | 237 |
| Overall height - K (mm) | 3027 | 3026 |
| Turning diameter, kerb to kerb (mm) | 18800 | 19600 |
| Turning diameter, wall to wall (mm) | 20400 | 21200 |
| Front track - M (mm) | | 2062 |
| Rear track - N (mm) | | 1815 |
| Approach angle - α (°) | 16 | 16 |
| Ramp angle - γ (°) | 15 | 14 |
| Departure angle - β (°) | 17 | 23 |
| Total vehicle kerb weight (kg) | 7987 | 8004 |
| Kerbweight on Front Axle (kg) | 4513 | 4536 |
| Kerbweight on Rear Axle (kg) | 3474 | 3468 |
| Gross Vehicle Mass - Plated (kg) | | 27600 |
| Gross Combination Mass - Plated (kg) | | 27600 |

*Indicative chassis tare mass with Standard options, without fuel, Adblue® and driver. $\pm 3\%$ tolerance apply.
Approximate mass of the optionals:
I. Transmission Intarder: 37kg

VERSION: 4 VERSION DATE: 05/2025

IVECO TRUCKS AUSTRALIA LIMITED TRADING AS IVECO TRUCKS NEW ZEALAND.
1 JERRY GREEN ST, WIRI, AUCKLAND 2104, NEW ZEALAND. PHONE: 0800 2 IVECO. WWW.IVECO.CO.NZ

THE INFORMATION IN THIS DOCUMENT WAS CORRECT AT THE DATE OF REVISION. THE DATA IN THIS DOCUMENT IS APPROXIMATE. IF AN EXACT WEIGHT OR DIMENSION IS REQUIRED PLEASE CONTACT IVECO NZ. ALWAYS CONSULT IVECO NZ FOR THE LATEST INFORMATION ON THE VEHICLE BEFORE DECIDING TO PLACE AN ORDER.

OVERSEAS IMAGES AND ILLUSTRATIONS ARE SHOWN THROUGHOUT THIS DOCUMENT AND IMAGES MAY REFER TO EQUIPMENT THAT IS OPTIONAL.
THE MODELS DESCRIBED CAN BE SUBJECT TO MODIFICATIONS WITHOUT ANY NOTICE BY THE MANUFACTURER