



Overseas model shown.

Illustration may contain optional features to the model.

ENGINE

Power: 310hp (228kW) @1675 - 2200rpm
Torque: 1300Nm @1100 - 1675 rpm

TRANSMISSION

Allison 3200 Full Automatic

MASS RATINGS

GVM: 27600kg
GCM: 27600kg

WHEELBASE

3800mm | 4200mm | 4500mm | 4800mm

KEY FEATURES

- Compliant to Euro VI STEP E Emission standard
- Advanced Emergency Braking System
- Adaptive Cruise Control
- Lane Departure Warning
- Full LED Headlights with cornering fog lights
- Climate control HVAC system

WARRANTY*

Standard Warranty
5 Years / 500,000km (whichever occurs first)

	Driveline Only	Driveline & other components
Driveline	•	
Driveline Plus	•	•

MAINTENANCE & REPAIR CONTRACTS*

	Maintenance	Friction	Repair
Service Bond	•		
Friction	•	•	
Easy Road	•	•	•

Contracts available up to 5 years/500,000kms (whichever occurs first)
*Please refer to the 'Standard Inclusions List' at your IVECO dealer.

ENGINE

Engine Model	Cursor 9
Total Displacement	8710cm ³
Maximum Power	310hp (228kW) @1675 - 2200rpm
Maximum Torque	1300Nm @1100 - 1675 rpm

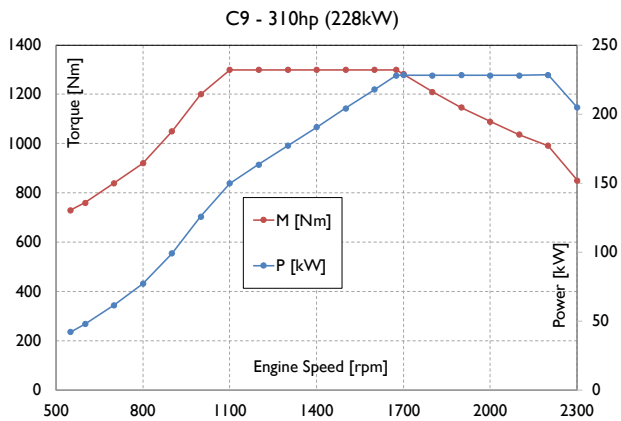

Injection type	Direct
Fuel Injection system	Common rail
Bore & Stroke	117 & 135mm
After-Treatment System	Hi-e SCR after-treatment system with DOC: Diesel Oxydation Catalyst DPF: Diesel Particulate Filter SCR: Selective Catalytic Reduction CUC: Clean Up Catalyst
Emission Compliance	Euro VI STEP E

TRANSMISSION

Description	Automatic Transmission
Make & Model	Allison 3200
Shifter type	Dash mounted electronic shifter with column mounted sequential shifter
Gear ratios:	1st: 3.49 5th: 0.75 2nd: 1.86 6th: 0.65 3rd: 1.41 Rev 5.03 4th: 1.00
Torque converter:	Allison TC-418
Stall torque ratio:	1.77

POWER TAKE-OFF

Rear engine PTO	Without Rear Engine PTO
Gearbox Power PTO	Side mount PTO - Equipped
PTO Control	Equipped with activation switch and electrics

REAR AXLE RATIO

Rear Axle Ratio	Standard: 5.67:1
-----------------	------------------

PERFORMANCE

Engine RPM @ 100km/h	1870
Road speed limiter	100km/h, Conforms to ADR65
Gradeability ¹ @ Rated GVM	34%

¹This is theoretically calculated. Actual performance may vary under different conditions.

AXLE & SUSPENSION

Front Axle Model & Type	IVECO 5890/D ON - Axle drop: 142mm
Front suspension	Parabolic suspension with dampers
FA & suspension capacity	8000kg
FA group mass rating	7100kg (with tyres)
Front Stabiliser bar	Diameter: ø40mm/ Roll rate: 2811Nm/Deg
Rear Axle Model & Type	MT23-150/D - Tandem Single reduction
Rear suspension	8 Bellow air suspension with ECAS Stroke: Raise/lower - 125mm/-65mm
Rear dampers	Equipped
RA & suspension capacity	23000kg
RA group mass rating	21000kg (with tyres)
Rear Stabiliser bar	Diameter: ø60mm/ Roll rate: 8247Nm/Deg
Axle load indicator	Equipped (with pneumatic suspension only)
Differential Cross Lock	Equipped
Road friendly suspension Certification	RFCN: RF2103

BRAKES & AUXILIARY BRAKES

Type/Control	Full air/Electronic Braking System (EBS) - ABS (Anti-lock Braking System) - ASR (Anti-Skid Regulator) - DPI (Direct Brake Integration) - BAS (Brake Assistant System) - BVR (Brake Lining Wear Adjustment) - ARB (Hill Holder) - ESC (Enhanced Stability Control)
Front axle	Ventilated Disc: Diameter 432mm/ Braking surface : 784cm ²
Rear axle	Ventilated Disc: Diameter 432mm/ Braking surface : 784cm ²
Engine brake with 3 level retardation	Equipped
Transmission Intarder	Equipped

CHASSIS

Dimensions	304.4x80x7.7mm
Chassis width (at rear)	771.4mm
Material	Steel
Tensile strength	610N/mm ²
Exhaust Pipe	Chassis mounted ATS & Horizontal pipe
Air Tanks	Aluminium
Front tow hook	Equipped
Towing cross member	N/A

WHEELS & TYRES

Rim Type	10-Stud disc wheel (ISO type) PCD 335mm Finish: Brushed Alloy
Rim size	22.5" x 8.25"
Tyre size	Front 295/80R22.5 Rear 295/80R22.5

FUEL & ADBLUE® TANK

Fuel Tank with lockable cap	290L
AdBlue® Tank	50L

FUEL SAVING FEATURES

Engine idle cut off	Equipped
EcoSwitch	Equipped

SAFETY FEATURES

Electronic Stability Programme (ESP)	Equipped
Anti-lock Brake System (ABS)	Equipped
Anti-slip Regulator (ASR)	Equipped
Advanced Emergency Braking System (AEBS)	Equipped
Adaptive Cruise Control (ACC)	Equipped
Lane Departure Warning System (LDWS)	Equipped
Reverse Buzzer	Equipped
Daytime Running Lamp (DRL)	Equipped
ECE-R29 Cab Strength Certification	Equipped
ECE-R93 Front Underrun Protection (FUP)	Equipped

ELECTRICAL & ELECTRONICS

Voltage	24V System
Batteries	2x 12 Volt/170Ah Batteries
Electrical battery cutout	Equipped
Battery position	Horizontal on side frame - LHS
Alternator	28 Volt/90A
Fleet Management System data interface (FMS)	Equipped
Chassis mounted jump start plug	Equipped
CAN OPEN Bodybuilder interface	Equipped
LED Headlamp - Low beam	Equipped
LED Headlamp - High beam	Equipped
Daytime Running Lamp (DRL)	Equipped
Fog light with cornering & bending	Equipped
Provision for roof rotating lights	Equipped with harness & switch in cab
Chassis mounted pneumatic horn	Equipped

STEERING

Dual control steering system with cross shafts	Equipped
Steering wheel	Soft touch steering wheel with following: - Controls for the phone - Controls for ACC (Adaptive cruise control) - Controls for radio/media volume
Steering angle	Inside: 52° Outside: 36°

SERVICE INTERVALS

Engine oil change interval ²	50,000km/12 Months
---	--------------------

²Based on normal operating conditions and may be reduced when operating under severe conditions.

CAB EXTERIOR

Cab type	Low roof Day cab (AD)
Cab tilt mechanism	Servo assisted cab tilt mechanism
Cab mounting	Mechanical suspension front & rear
Windscreen Wipers	Automatic - Rain sensing 2 Speed with Integrated Washer Nozzles
Front Bumper	Multi-piece Plastic front bumper with foldable step Optional: Multi-piece hybrid front bumper with foldable step
Rearview mirrors	2 x Motorised, heated flat main mirrors & convex spotters 1 x LHS kerb view & front view mirrors

External Sunvisor	Equipped
Colour	White IC 194

CAB INTERIOR

Seating capacity	Two
Driver Seat	Fabric, Air suspended, Heated, 3-Way adjustable seat
Passenger Seat	Fabric, Air suspended, Heated, 3-Way adjustable seat
Seat Belt	3-point Lap/Sash type
Sun visor & overhead consoles	Equipped on both driver & Passenger side
Multimedia unit	DAB Radio with Bluetooth connectivity
HVAC System	Equipped - with climate control
Immobiliser	Equipped - with 3 x remote central lock keys
Power Windows	Equipped
Cup holders	Equipped
Interior lighting	LED Internal Lights
Rollup sun blinds for doors	Equipped

GENUINE ACCESSORY OPTIONS

- Phone Cradle	- Rubber Floor Mats
- Cameras	- Seat Covers
- Foot Well Liners	- 24 to 12 Volt Voltage Reducer

Please check with your dealer for availability and price.

IVECO TELEMATICS

Telematics Hardware	Equipped (GSM & GPS & Antenna & 4G SIM) with provision for mobile cradle. Upon subscription. Features include: - MYIVECO Smart report
Smart connectivity pack (Included for 5 years)	- MYIVECO Web portal & mobile app - MYIVECO Vehicle monitoring & remote assistance - MYIVECO Easy Way app
Premium pack	Optional

MODEL CODE: AD230A3 IZ/P DUAL

Application: Rigid

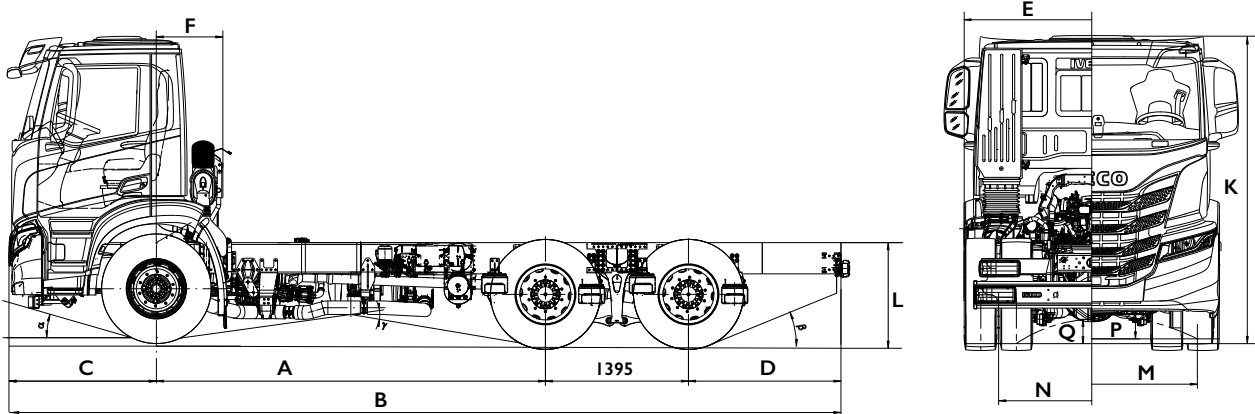

DIMENSIONS & WEIGHTS

Wheelbase - A (mm)	3800	4200	4500	4800
Max length - B (mm)	8179	8224	9349	9169
Max width over fenders - E (mm)			2500	
Front axle to back of cab - F (mm)			755	
Frame height at end of frame, unladen - L (mm)	1030	1029	1031	1029
Front overhang - C (mm)			1410	
Rear overhang - D (mm)	1488	1128	1983	1488
Minimum ground clearance, front - P (mm)			231	
Minimum ground clearance, rear - Q (mm)			237	
Overall height - K (mm)	3029	3027	3027	3026
Turning diameter, kerb to kerb (mm)	17200	18200	18800	19600
Turning diameter, wall to wall (mm)	18800	19800	20400	21200
Front track - M (mm)			2062	
Rear track - N (mm)			1815	
Approach angle - α (°)	16	16	16	16
Ramp angle - γ (°)	17	15	14	13
Departure angle - β (°)	23	30	17	23
Total vehicle kerb weight (kg)	7848	7951	8017	8009
Kerbweight on Front Axle (kg)	4464	4477	4463	4495
Kerbweight on Rear Axle (kg)	3384	3474	3554	3514
Gross Vehicle Mass - Plated (kg)			27600	
Gross Combination Mass - Plated (kg)			27600	

*Indicative chassis tare mass with Standard options, without fuel, Adblue® and driver: $\pm 3\%$ tolerance apply.

VERSION: 3 VERSION DATE: 05/2025

IVECO TRUCKS AUSTRALIA LIMITED TRADING AS IVECO TRUCKS NEW ZEALAND.
1 JERRY GREEN ST, WIRI, AUCKLAND 2104, NEW ZEALAND. PHONE: 0800 2 IVECO. WWW.IVECO.CO.NZ

THE INFORMATION IN THIS DOCUMENT WAS CORRECT AT THE DATE OF REVISION. THE DATA IN THIS DOCUMENT IS APPROXIMATE. IF AN EXACT WEIGHT OR DIMENSION IS REQUIRED PLEASE CONTACT IVECO NZ. ALWAYS CONSULT IVECO NZ FOR THE LATEST INFORMATION ON THE VEHICLE BEFORE DECIDING TO PLACE AN ORDER.

OVERSEAS IMAGES AND ILLUSTRATIONS ARE SHOWN THROUGHOUT THIS DOCUMENT AND IMAGES MAY REFER TO EQUIPMENT THAT IS OPTIONAL.
THE MODELS DESCRIBED CAN BE SUBJECT TO MODIFICATIONS WITHOUT ANY NOTICE BY THE MANUFACTURER