

EUROCARGO



PERFECT IN EVERY SITUATION

IVECO



## C O N T E N T S

---

6. VERSATILITY

12. DESIGN

16. COMFORT & ERGONOMICS

20. SAFETY

24. PERFORMANCE

26. RELIABILITY

30. SERVICES

32. EURO CARGO

34. IVECO NEW MEDIA

35. EURO CARGO COLOURS

All the information and details you might want about the range are available on the IVECO website.

Take a closer look at the world of Iveco on:  
**[www.iveco.co.za](http://www.iveco.co.za)**

The information and images contained in this catalogue are provided by way of example. IVECO reserves the right to make changes for any commercial or construction reasons at any time without notice.

# EURO C A R G O



VERSATILITY



DESIGN



COMFORT  
& ERGONOMICS



SAFETY



PERFORMANCE



RELIABILITY



SERVICES









V E R S A T I L I T Y



# V E R S A T I L I T Y

**For every job, there's a EUROCARGO cut out for it.**

Because the EUROCARGO range is the most extensive in its class:

- ⊕ **8 gross vehicle weight variants** (from 9 to 18 tonnes)
- ⊕ **4 power ratings** (from 180 to 280 HP)
- ⊕ **7 transmissions** (six manual, and one automatic)
- ⊕ **2- and 4-wheel drive**
- ⊕ **12 wheelbases** (from 3,105 to 6,210 mm)
- 3 types of cab.**

And because you can specify each variant with a choice of suspensions, axles and final drive ratios, the EUROCARGO range offers an incredible total of over 1,000 permutations, a 1 | 1 with the guarantee of IVECO know-how, technology and manufacturing processes.

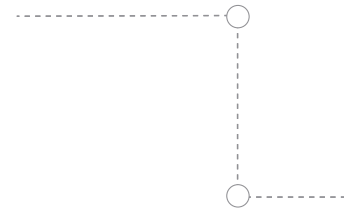

CAB WITH 1 STEP

CAB WITH 2 STEPS

CAB WITH 1 STEP

CAB WITH 2 STEPS

MLC - SHORT, LOW ROOF

MLL - LONG, MEDIUM ROOF



MLL - LONG, LOW ROOF



**CAB  
WITH 1 ACCESS STEP**  
for 9- to 10-ton versions



MODEL	GVW	GCW	ENGINES	GEARBOXES	CABS	WHEELBASES
<b>ML100E [90E]</b>	9-10 t	18 t	6 cil, 180 HP	Manual	MLC (short) MLL (long)	3105-4815 mm

**CAB  
WITH 2 ACCESS STEPS**  
for 12- to 18-ton versions



MODEL	GVW	GCW (*)	ENGINES	GEARBOXES	CABS	WHEELBASES
<b>ML140E [120E]</b>	12-14 t	26 t	6 cil, 220 HP	Manual	MLC (short) MLL (long)	3105-4815 mm
<b>ML150E [170E]</b>	15 t	15-17 t	6 cil, 220-240 HP			3105-51755 mm
<b>ML180E</b>	18 t	32.5 t	6 cil, 280 HP	Manual Automatic		3690-6210 mm

(\*) Trailer versions not available with automatic

**4X4 WITH 2  
ACCESS STEPS**  
for 11.5- and 15-ton versions



MODEL	GVW	GCW	ENGINES	GEARBOXES	CABS	WHEELBASES
<b>ML150E... W</b>	15 t	21 t	6 cil, 240	Manual	MLC (short) MLL (long)	3240-4150 mm



## V E R S A T I L I T Y

**EUROCARGO's adaptability to** every need means you'll always find the right conversion for your business. The range includes box vans and curtain-siders for **high load capacity**, temperature-controlled boxes and three-way tippers for **ease of transformation**, tankers and mobile shops for **agility and low emissions**; lift platforms, high-access platforms, fire and rescue conversions, compact concrete mixers, and sweepers for refuse collection, cleaning and **maintenance services**.

**EUROCARGO is a first choice for public sector agencies** and municipal service contractors because of its adaptability to a wide range of jobs. The **parallel rail chassis** frame in **high-yield-strength steel** is free from obstructions on top and can accommodate body lengths of between 4,265 and 9,000 mm. The equidistant holes drilled in the rails optimise the time and cost of fitting superstructures and machinery, without compromising the corrosion treatment of the frame.

EUROCARGO also offers an extensive range of electro-actuated power take-offs with maximum torque delivery of up to 900 Nm.

**The flexibility of EUROCARGO, combined with its structural strength,** gives it unbeatable driveability wherever it goes:

- ⊕ **in city centres** it's outstandingly agile thanks to its cab width of just 2.28 metres, steering angle of 52 degrees and tight turning circle (less than 12.5 metres with a 3,105 mm wheelbase).
- ⊕ **for combined-cycle and motorway driving** it's stable and secure even in the event of unexpected manoeuvres, while the power and flexibility of its engines ensure high commercial speeds.
- ⊕ **on demanding road surfaces** or in extreme climates, it's ready for anything, thanks to the natural, stress-free handling afforded by its exceptionally robust structure and class-leading safety equipment.







# V E R S A T I L I T Y



MODEL	WHEELS TWIN 10R22.5				WHEELS SINGLE 395/85R20				WHEELS SINGLE 395/85R20			
	3240	3690	3915	4150	3240	3690	3915	4150	3240	3690	3915	4150
<b>Wheelbase [mm]</b>	3240	3690	3915	4150	3240	3690	3915	4150	3240	3690	3915	4150
<b>Ramp breakover angle [degrees]</b>	21	19	18	18	22	22	21	21	23	23	22	22
<b>Departure angle [degrees]</b>	16	16	16	11	16	16	16	12	17	17	17	13
<b>Approach angle [degrees]</b>	28				31				32			
<b>Ground clearance [mm]</b>	337				392				428			
<b>Lateral gradient [degrees]</b>	30				28				26			
<b>Maximum climbable gradient ON ROAD</b>	38%				33%				31%			
<b>Maximum climbable gradient OFF ROAD</b>	>100%				>80%				>74%			
<b>Wading depth up to [mm]</b>	489				542				578			

**With EUROCARGO 4X4, strength knows no limits.**

Designed for the most demanding off-road work, EUROCARGO 4x4 incorporates a specific series of solutions for protecting its structure: **steel bumpers**, retractable access steps and a **specific radiator guard**. Available with a short or long cab with low roof, it has a gross vehicle weight of 11.5 or 15 tonnes and a range of wheelbases measuring from 3,240 to 4,150 mm. EUROCARGO 4x4 utilises a 6-cylinder Tector engine in 240 HP. The ZF six-speed manual gearboxes are fitted with a **servoshift system** for easy gear-changing even in the most demanding work conditions.

Permanent four-wheel drive is provided by a longitudinal differential, which distributes torque between the front and rear axles. What's more, you can select a fast or slow distributor ratio, according to conditions (on / off road). All the differentials are equipped with a manually operated locking system to ensure traction even in especially adverse, low-grip conditions. EUROCARGO 4x4 is fitted with a double-reduction rear axle and is available in versions **with single** or **twin wheels**. Braking comes courtesy of simplex drum brakes on the rear axle and duplex drums up front, while you can specify either parabolic or semi-elliptical leaf spring suspension.

EUROCARGO 4x4 is at home anywhere. The outstandingly low emissions of the engines and the excellent steering angle (from 40° to 48° depending on tyres) enable you to use it on urban construction sites too.

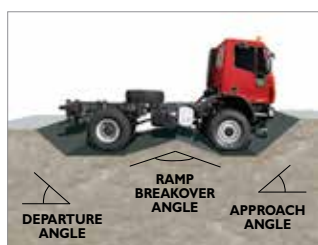





## D E S I G N

**It's clear at first sight that EURO CARGO is a solid, dynamic, modern vehicle,** with an unmistakable shape and strong character. The front features an **imposing grille equipped** with non-slip steps for washing the windscreen, a bumper with built-in light clusters (grouped together for ease of maintenance) and a large space for your company's logo above the IVECO badge.

The bumpers and mudguards are also available in the same colour as the body. And if you're buying your vehicle for off-road work, you can specify a one-piece steel bumper. Both sides of the long cab feature remote electric hatch release hatches that give access to two illuminated storage boxes with total capacity of 260 litres. Getting in and out of the cab is safe and easy, thanks to the **large handles** and **illuminated non-slip steps**. And six rear-view mirrors ensure maximum visibility in all directions.











C O M F O R T   A N D   E R G O N O M I C S



## C O M F O R T & E R G O N O M I C S

For IVECO, human-centred design means offering **productivity, ergonomics, practicality and comfort in a single package.** Climb into a EUROCARGO cab, and you'll see that everything is clear, simple and in easy reach. The layout of the functions is simple and intuitive, with all the **instruments directly in front of the driver,** all the controls in the steering wheel area, and the most frequently used buttons grouped together on the dashboard in the most accessible positions.

The gear stick is built into the compact, linear dashboard, making it quicker and easier to cross from one side of the cab to the other (essential for urban work).

The storage compartments are made of soft-touch materials and located in easily accessible positions in various areas of the vehicle. The interior door panels, meanwhile, have large storage pockets.

The power take-offs are managed by an ECU (Expansion Module), which is operated by the driver by means of a dash-mounted switch. This too helps optimise productivity, reliability and safety.

**The cab componentry and ergonomics** are designed to ensure the ideal driving position. You can operate the steering column combination-switch controls without taking your hands off the steering wheel, and they're grouped together on just two levers, which incorporate the automated transmission gear selector. **The seats and steering wheel are easy to adjust.**

The buttons controlling the electric windows and mirrors are located in the arm-rests built into the door panels. The optional sat-nav system is housed in the middle of the dashboard.

On the instrument panel, you can keep a constant eye on all key vehicle and route parameters, such as fuel level, tyre pressure, fuel consumption, maintenance deadlines, travelling times and average speed.







# COMFORT & ERGONOMICS

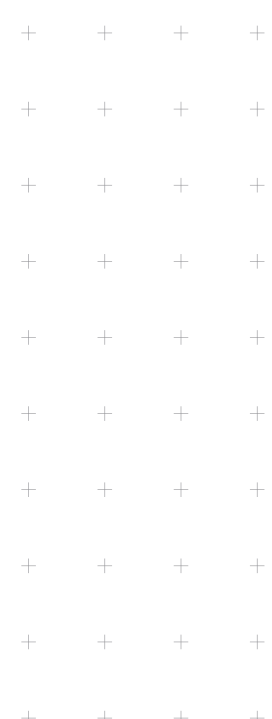
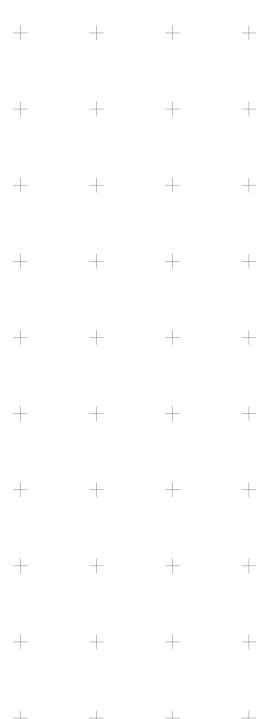

**For maximum quality of life on board on every job,**

EUROCARGO is available with 3 different types of cab;

- ⊕ **short** (MLC) for distribution and short-haul work or when body length is a priority,
- ⊕ **long, with low or high roof** (MLL) for long-haul work and jobs involving overnight stops.

Every cab can be fitted with air conditioning and a programmable heater, so that you can quickly get the cab temperature you want, with optimum air distribution.

The interior lighting is very practical, thanks to the two ceiling-mounted spot-lights.

**Eurocargo's seats, upholstered in either cloth, or PVC,** ensure the highest levels of strength and practicality.

The long-cab version is equipped with 1 or 2 bunks (an extra-size single bunk is available as an option) and can be fitted with a fridge or insulated cool-box.



On the version with double passenger seat, the central back-rest can be folded completely flat.

The sleeping area features an angle-adjustable lamp and a **“bed module”**, for controlling the lighting and air conditioning, and opening and closing the doors, windows and skylight.

High-quality materials and finishes give the EUROCARGO cab an **elegantly practical look**. And the excellent sound insulation makes it an ideal environment for working and relaxing.

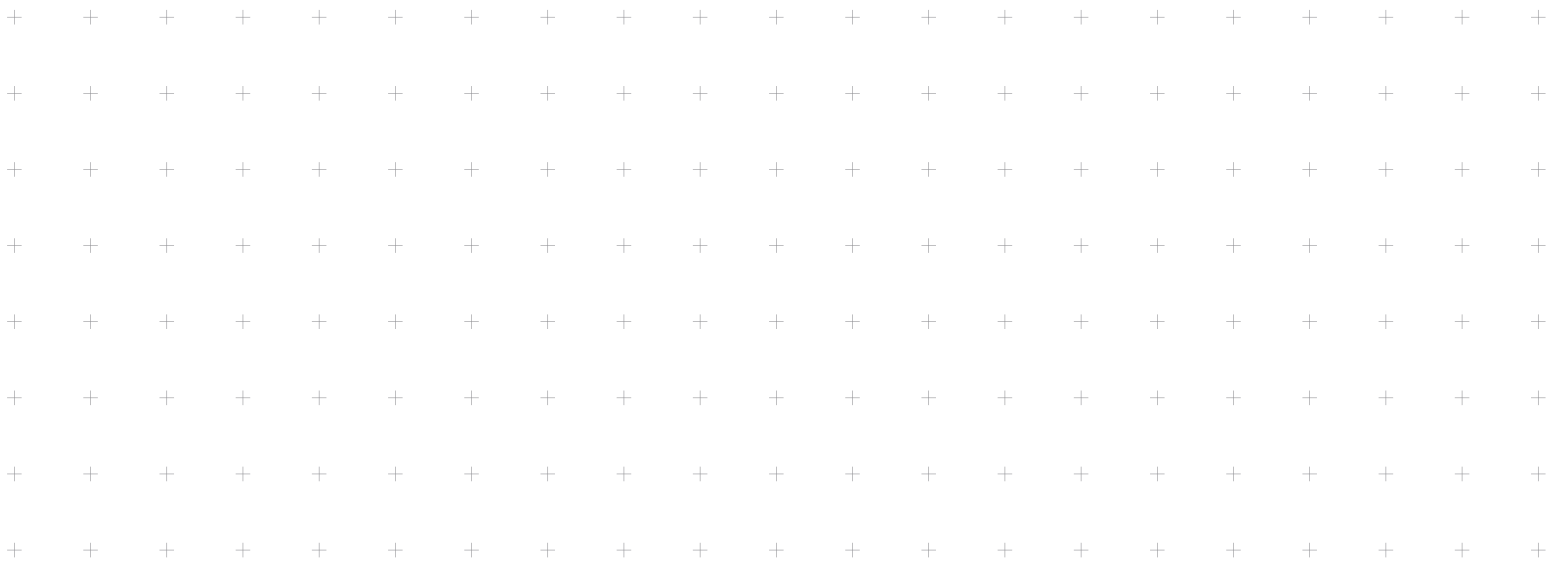



# S A F E T Y





**The safe side of versatility.** When it comes to commercial vehicles, safety means a lot of things: safety for the people on board, for other road-users, for the vehicle's cargo and for the value of your investment.

IVECO has a multiple approach to safety: on the **passive safety** front, its cabs provide effective protection for occupants in the event of an impact; on the **active safety** front, EURO CARGO offers class-leading road-holding and braking distances; and in terms of **preventive safety**, the driver-centred cab reduces fatigue and stress. **Latest-generation electronic systems** also make a major contribution to safety. All models are fitted with ABS as standard, and you can specify other electronic safety systems as options.







P E R F O R M A N C E





# P E R F O R M A N C E

**The secret of EUROCARGO's Tector engines lies in their flexibility:** with consistently high levels of torque across a wide rev range, they ensure fluid progress, fewer gear shifting, less engine wear and higher energy-efficiency.

EUROCARGO's diesel engines are turbocharged, common rail units with waste-gate, available in one displacement 5.9-litre with 6 cylinders and four power ratings (from 180 to 280 HP, with maximum torque ranging from 570 to 930 Nm).

**All EUROCARGO engines** meet EURO 3 STANDARDS.

ENGINE	MAX POWER		MAX POWER ENGINE SPEED (rpm)	MAX TORQUE (Nm)	MAX TORQUE RANGE (rpm)
	(kW)	(HP)			
<b>TECTOR 6 - E18</b>	134	182	2700	570	1300-2100
<b>TECTOR 6 - E22</b>	160	217	2700	680	1200-2100
<b>TECTOR 6 - E24</b>	176	240	2700	810	1250-2100
<b>TECTOR 6 - E28</b>	202	279	2500	930	1250-2100

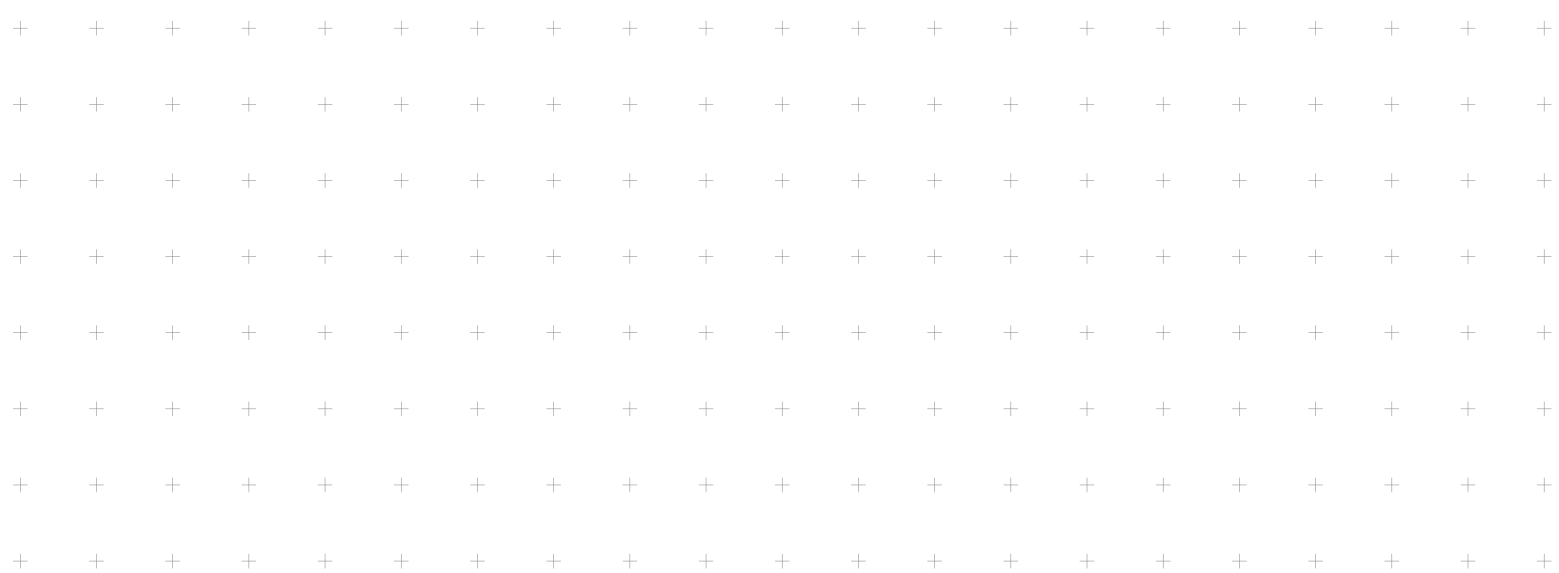

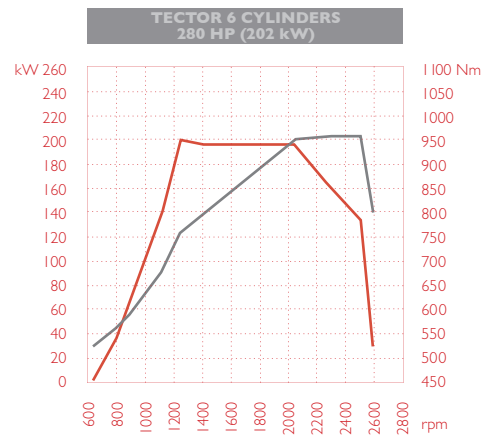
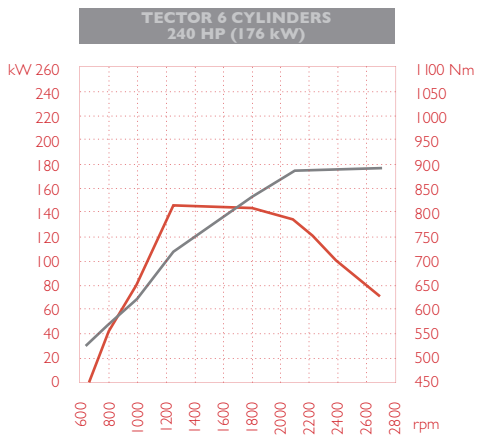
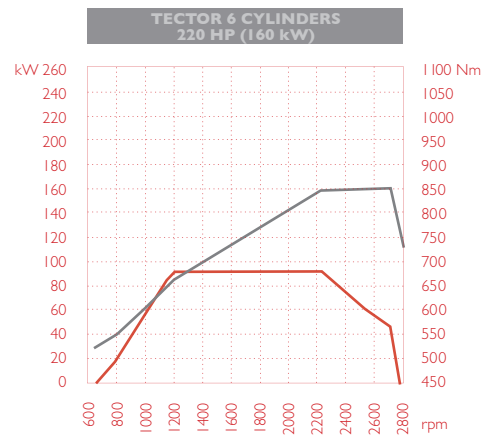
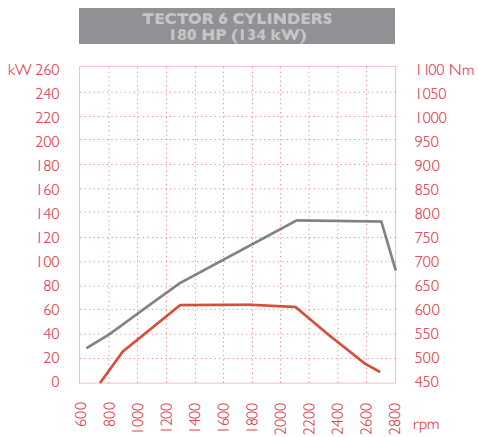

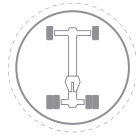

# R E L I A B I L I T Y





**Changing gear can have a major effect on vehicle performance and fuel consumption.**

EUROCARGO has the answer in the form of highly flexible engines, which minimise the need to change gear.

**Allison automatic transmission** with torque converter is available on the 18-tonne vehicles. These gearboxes offer unbeatable comfort for city use, where “stop & go” work is par for the course: since urban work involves about 1,200 gear changes a day, you can see how much stress and energy an auto box saves for the driver.

**The ZF manual transmissions** (with 6 and 9 speeds) are lighter and have an innovative calibrated synchronisation system, for outstanding ease of gear selection and longer life of mechanical components.

As well as a wide range of transmissions, EUROCARGO offers a wide range of rear axle ratios to suit every mission: the “long” ratios are ideal for out-of-town work at high speeds, and the “short” ratios are ideal when you need high levels of traction, such as on compactors.

GEARBOX	NO. OF SPEEDS	GEARBOX CODE	MAX TRANSMISSIBLE TORQUE (Nm)	WEIGHT (kg)	OIL QUANTITY (litres)
ZF Manual	6	ZF 6S700	700	100	7
		ZF 6S800	850	124	10.7
		ZF6S1005	1050	136	10.5
	9	ZF 9S-75 TD	770	125	10
		ZFF 9S-75 TO	900	125	10
		ZF 9S-1110	1100	190	8.8
Allison Automatic	5	Allison S3000	1261	260	25

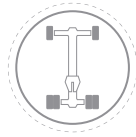

## R E L I A B I L I T Y

**To ensure long, trouble-free service-life,** EUROCARGO uses an **outstandingly strong frame**, with the mechanical qualities you'd expect from a heavy vehicle, but lower tare weight.

Thanks to its **H-structure in special steel** it can readily withstand the stresses generated by an unbalanced load or sudden change of trajectory.

EUROCARGO is available with **parabolic or semi-elliptical suspension, or air suspension** (with 4 bellows for the 18-tonne versions) with **ECAS system** (Electronically Controlled Air Suspension). ECAS ensures high levels of comfort at the wheel, and constant suspension geometry regardless of speed, load and type of road surface. It also acts on braking pressure, which is modulated according to the load on the axles.

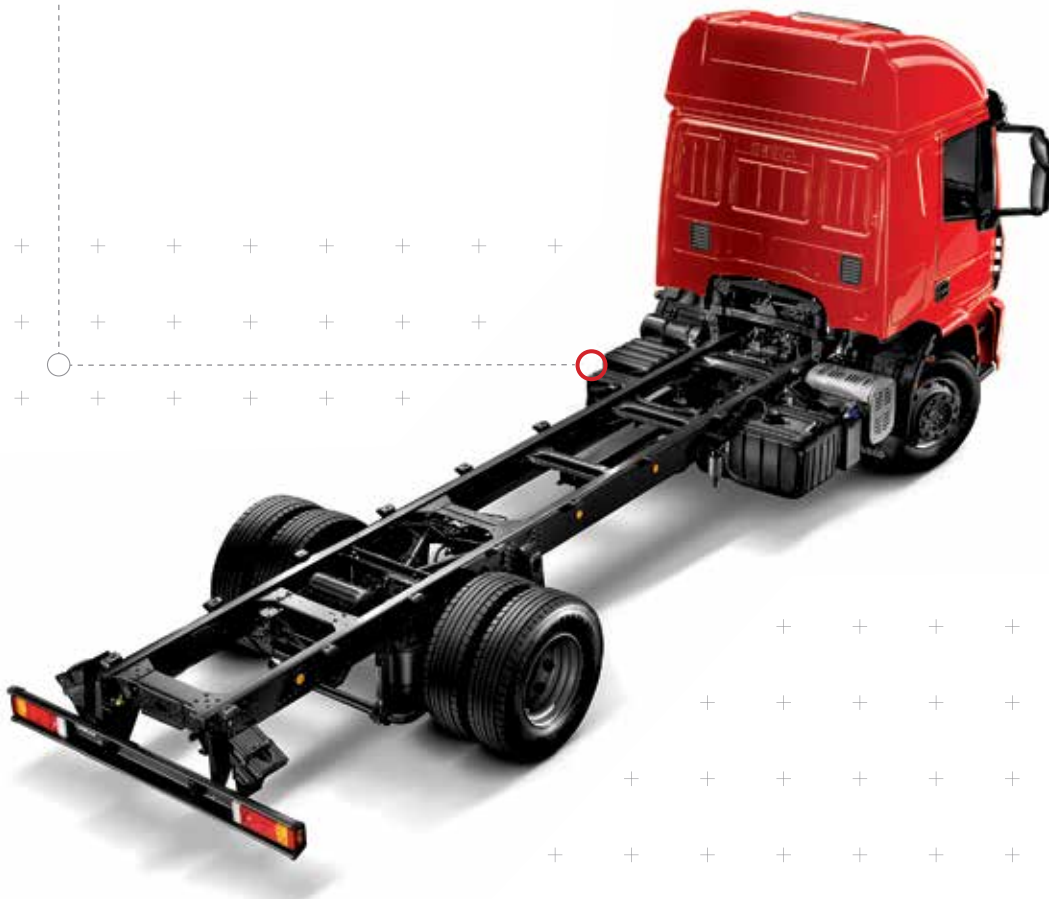

Developed on the strength of IVECO's long experience in heavy haulage, quarry and construction vehicles, the **front and rear axles and braking system** ensure high **reliability** and consistent performance over time.

A technologically advanced braking system ensures the safety of the vehicle's occupants and cargo alike.

**The braking system is hydro-pneumatic** on the 9- to 10-tonne range and fully pneumatic on the 12- to 18-tonne range. With the availability of a wide range of options, vehicle configurations can be tailored to your specific applications and most frequently used routes, thus ensuring safety and comfort in all surface conditions.

The whole EURO CARGO range is equipped with a standard engine-brake.

You can select engine-brake operating mode (on accelerator pedal release or on brake pedal application) by means of a lever on the right of the steering column.





## S E R V I C E S

### **YOUR VEHICLE IN GOOD HANDS**

Any professional driver knows how essential it is to be able to count on someone with the right skills and equipment to take complete care of their vehicle. Which is why IVECO - the designer and builder of your vehicle - guarantees you **the very best assistance**. IVECO offers you products and services of tried and tested excellence, provided by an extensive support network of technicians and professionals trained to deliver solutions, whatever the job or the situation. In addition, using the IVECO Service Network, you also benefit automatically from the **IVECO Original Parts Warranty**. This means maintaining the tip-top performance of your vehicle and your business in the long term. Select your nearest IVECO dealer or workshop, using the locator on the website: [www.iveco.co.za](http://www.iveco.co.za)

### **ORIGIN: A CERTIFIED QUALITY SYSTEM**

Origin 100% IVECO is the chain of excellence through which the company certifies and guarantees the total quality of the entire procurement and distribution cycle for its original parts, and the expertise of its Service Network. Because Origin 100% IVECO is more than a brand - it is our philosophy.

### **THE PERFORMANCE OF YOUR IVECO REMAINS UNCHANGED OVER TIME**

The excellence of IVECO performance is guaranteed over time thanks to the use of **original parts**, designed by the same experts who built your vehicle.

### **INTENSIVE AND RIGOROUS TESTING**

The quality of IVECO Original Parts is certified through specific, rigorous and meticulous tests: the only way to be 100% certain of their exceptional quality and durability.



**IVECO SHOP: DETAILS MAKE THE DIFFERENCE**

IVECO Shop has created a comprehensive line of accessories tailored to suit your vehicle, your mission and your tastes. With these, you can customize your IVECO, making it even more stylish, comfortable, safe and technological. Exterior, interior, safety, comfort and hi-tech accessories: everything you could possibly need is right here. The choice is yours. Have a good trip.

**AN EXTENSIVE, PROFESSIONAL NETWORK FOR A CONSTANTLY EFFICIENT VEHICLE**

IVECO workshops provide the manufacturer's quality combined with the skill of technicians who know your vehicle like no-one else. Specialised diagnostic and repair equipment such as E.A.S.Y. and its accessories Easy Scope & Easy Skite guarantee speed and efficiency even for remote assistance (teleservices).



**THE ORIGIN 100% IVECO TEAM: individual excellence ensures total excellence. Always, 100%.**

Customers choose the best. Origin 100% IVECO workshops demonstrate their excellence every day, with the Team as an exclusive point of reference, the only service with the credentials to achieve 100% customer satisfaction. Always. The specific skills of individuals and their unique values come together in the Team. The result is total efficiency, work of the highest standard and tremendous strengths: skill, understanding, helpfulness and quality repairs performed without delay. These are the winning formula.





VERSATILITY

**11,584 POSSIBLE VARIANTS**

9 TRANSMISSIONS  
3 TYPES OF CAB WITH  
12 WHEELBASES

**LARGE HANDLES**  
**ILLUM**



SAFETY

ACTIVE, PASSIVE AND PREVENTIVE SAFETY

**LATEST-GENERATION ELECTRONIC SYSTEMS**

ABS AS STANDARD ON ALL MODELS

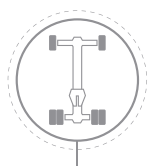

RELIABILITY

ALLISON AUTOMATIC, ZF MANUAL TRANSMISSIONS

**OUTSTANDINGLY STRONG FRAME FOR LONG, TROUBLE-FREE SERVICE-LIFE**

SUSPENSION WITH ECAS



# CARGO



## DESIGN

IMPOSING GRILLE

**AND ILLUMINATED, NON-SLIP STEPS**  
**ILLUMINATED STORAGE BOXES**



## COMFORT & ERGONOMICS

3 TYPES OF CAB

**ERGONOMICALLY**

**POSITIONED INSTRUMENTS**  
CUBBY HOLES AND STORAGE  
COMPARTMENTS IN SOFT-TOUCH  
MATERIALS



## PERFORMANCE

**VECTO R ENGINES**



## SERVICES

ELEMENTS TAILORED ASSISTANCE PROGRAMMES  
ORIGIN 100% IVECO

# I V E C O   N E W   M E D I A

**IVECO was the first manufacturer to construct and develop a profile in the** world of social networking, with an up-to-date, coordinated presence and unique global access.

**The Internet and social networking presence is a service that IVECO provides to its customers to guarantee** more extensive and instantaneous information on products, services, technologies, events and sales promotions.

To find out more about the EURO CARGO, visit:

[www.iveco.co.za](http://www.iveco.co.za)



[www.facebook.com/lvecoSouthAfrica](http://www.facebook.com/lvecoSouthAfrica)



[www.youtube.com/iveco](http://www.youtube.com/iveco)



[www.flickr.com/photos/iveco1975](http://www.flickr.com/photos/iveco1975)



# EUROCARGO COLOURS



50126  
MARANELLO RED



50173  
ALPS WHITE



50174  
GARLENDA RED



50162  
MINERAL GREY



50105  
WHITE



50177  
ALSACE GREEN



50178  
MARRAKESH YELLOW



50179  
LION BLUE



50180  
CARRARA IVORY



50181  
PRAGUE YELLOW



50182  
ISTANBUL BLUE



52301  
DESERT ORANGE

**IVECO**

[WWW.IVECO.CO.ZA](http://WWW.IVECO.CO.ZA)